

## ANSI 600# Female Ring Joint

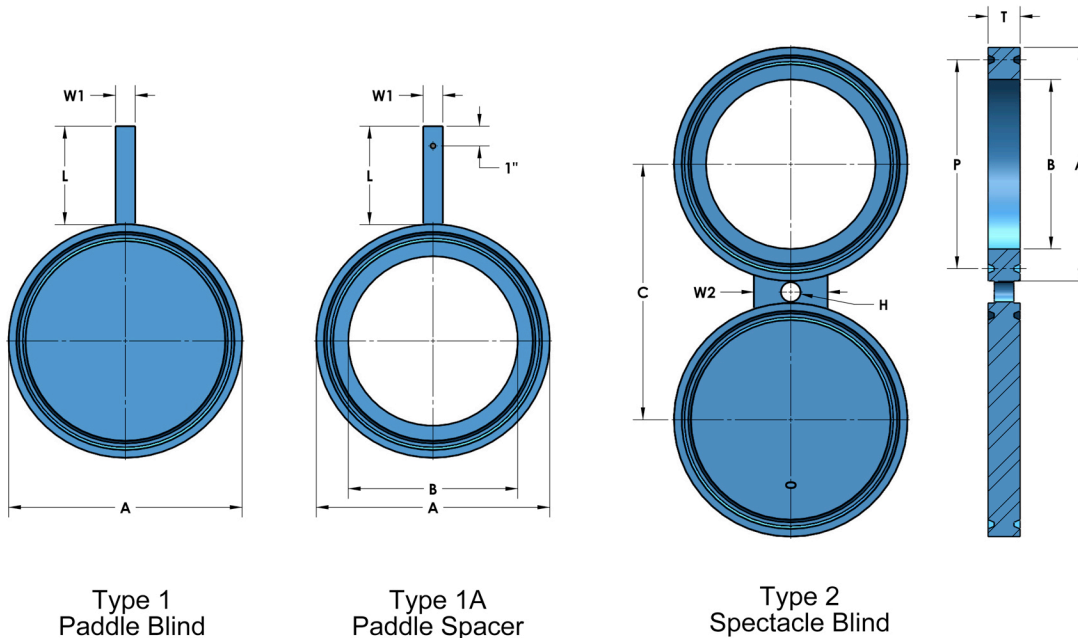

Dimensional Data (in)											Approximate Weights (lbs)		
Size	A	B	C	T	P	L	W1	W2	H	Ring	1	1A	2
1/2	2.00	0.84	2.62	0.75	1.344	4	1.0	1.50	0.625	R 11	1	1	1
3/4	2.50	1.05	3.25	0.88	1.688	4	1.0	1.75	0.750	R 13	1	1	1
1	2.75	1.32	3.50	0.88	2.000	4	1.0	2.00	0.750	R 16	2	1	2
1 1/4	3.12	1.66	3.88	0.88	2.375	4	1.0	2.00	0.750	R 18	3	3	4
1 1/2	3.56	1.90	4.50	0.88	2.688	4	1.0	2.25	0.875	R 20	4	3	6
2	4.25	2.38	5.00	1.12	3.250	4	1.0	2.25	0.750	R 23	6	4	9
2 1/2	5.00	2.88	5.88	1.25	4.000	4	1.0	2.25	0.875	R 26	8	6	13
3	5.75	3.50	6.62	1.25	4.875	4	1.0	2.25	0.875	R 31	11	7	16
3 1/2	6.25	4.00	7.25	1.38	5.188	4	1.0	2.50	1.000	R 34	13	9	20
4	6.88	4.50	8.50	1.38	5.875	5	1.0	2.50	1.000	R 37	16	10	24
5	8.25	5.56	10.50	1.50	7.125	5	1.0	2.75	1.125	R 41	24	15	39
6	9.50	6.62	11.50	1.75	8.312	5	1.0	3.25	1.125	R 45	36	20	53
8	11.88	8.62	13.75	2.00	10.625	6	1.0	3.75	1.250	R 49	65	32	95
10	14.00	10.75	17.00	2.25	12.750	6	1.0	4.00	1.375	R 53	98	42	137
12	16.25	12.75	19.25	2.50	15.000	6	1.5	4.75	1.375	R 57	146	58	202
14	18.00	14.00	20.75	2.62	16.500	6	1.5	5.00	1.500	R 61	165	67	229
16	20.00	16.00	23.75	2.88	18.500	7	1.5	5.00	1.625	R 65	225	83	386
18	22.62	18.00	25.75	3.12	21.000	7	1.5	5.00	1.750	R 69	367	137	502
20	25.00	20.00	28.50	3.50	23.000	7	1.5	5.00	1.750	R 73	499	182	679
24	29.50	14.00	33.00	4.12	27.250	8	1.5	6.00	2.000	R 77	814	278	1094